

PANcharge[®] 1k

Battery Charger

User's Manual





Table of Contents

1. Important Safety Instructions	3
1-1 General Safety Precautions	3
1-2 Battery Precautions	4
1-3 Electromagnetic Disturbance	4
2. Features	5
2-1 Mechanical Drawings.....	5
2-2 Front Panel.....	5
2-3 Rear Panel	5
2-4. Specification	6
3. Installation and Settings	7
3-1. Installation location	7
3-2. Battery Type	7
3-3. Connection and Setting	8
4. Operation	10
4-1. 3 Stage Charging.....	10
4-2. Operation and LED Indicators.....	11
4-3. LED Indicator of Error	12
4-4. Protection	12
5. Troubleshooting	13
6. Warranty.....	14

1. Important Safety Instructions

This document contains important safety and operating information for PANcharge1k. To work PANcharge1k the best, use inverter only as described in safety instructions. Carefully read through the safety instructions before mounting PANcharge1k.

 WARNING	This sign indicates the following contents includes important information. The wrong order of handling may lead to the risk of death or seriously injured.
--	--

 CAUTION	This sign indicates the following contents includes important information. The wrong order of handling may cause damage to the products and the surrounding stuff.
--	--

 NOTE	This sign indicates the following contents includes important information of manuals about functions which contains safety instructions or proper operation of PANcharge1k.
---	---

1-1 General Safety Precautions

 WARNING	Read following safety instructions carefully before installation.
---	---

- Save these instructions of PANcharge1k battery charger and batteries. This manual contains important safety and operating instructions.
- Operate PANcharge1k in a well-ventilated and dry area. Do not exposed to rain or snow.
- To reduce a risk of fire, do not cover or obstruct the ventilation enclosure.
- To avoid a risk of fire and electric shocks, do not operate charger with damaged or undersized cords.
- To avoid the risk of fire and electric shocks, do not disassemble charger.

 NOTE	Warranty not valid once PANcharge1k is disassembled.
---	--

To reduce the risk of electric shock, follow the steps below before wiring, maintenance and cleaning.

- Turn AC power switch off.
- Remove AC power cord from the charger.
- First remove the black charging clip from the battery then the red one.
- By covering charging clips to avoid short circuit of charging terminal while turning switch ON.

Ground the earth cord with the power cord to reduce the risk of electric shock, to protect from external radio interference and not to radiate harmful emissions. The earth cord is connecting with the charger's chassis.

To avoid the risk of electric shock and fire, adjust the AC power switch in the rear of the charger to the same voltage as the input one. Plug the proper power cord to the plug-in. NEVER input 230Vac with the 115Vac setting. It may lead to a fire, electric shock, or charger damage.

 NOTE	Once PANcharge1k is opened or modified, DENRYO CO., LTD. has the right not to provide warranty service.
---	---

1-2 Battery Precautions

- Read the instructions of battery carefully before operating.
- Place battery in a well-ventilated and dry area. Do not exposed to rain or snow.
- NEVER smoke or allow a spark or flame in vicinity of battery.
- Be extra cautious to reduce risk of dropping metal tool onto battery. Remove personal metal items such as rings, necklaces, and watches when working with battery.
- The battery may make corrosive gas during charging. Keep ventilation well.

Protect eyes and clothes when you work close to battery. Do not get too close to the battery with your eyes. When moving the battery, removing wiring from the earth terminal at first. Make sure all the optional accessories have been turned OFF to reduce the possibility of sparking.

1-3 Electromagnetic Disturbance

This charger is designed under the consideration of electromagnetic interference radiation and immunity. However, installing without following this manual may cause the Interfere with radio communication. Operation of this equipment in a residential area is likely to cause harmful interference. When the interference happens because of the ON/OFF of the charger, follow one of the steps below to solve the problem.

- Reset the direction of receiver antenna or adjust the mounting location.
- Set the charger apart farther from the receiver.
- Do not connect the receiver and charger into in the same wall sockets.

2. Features

2-1 Mechanical Drawings

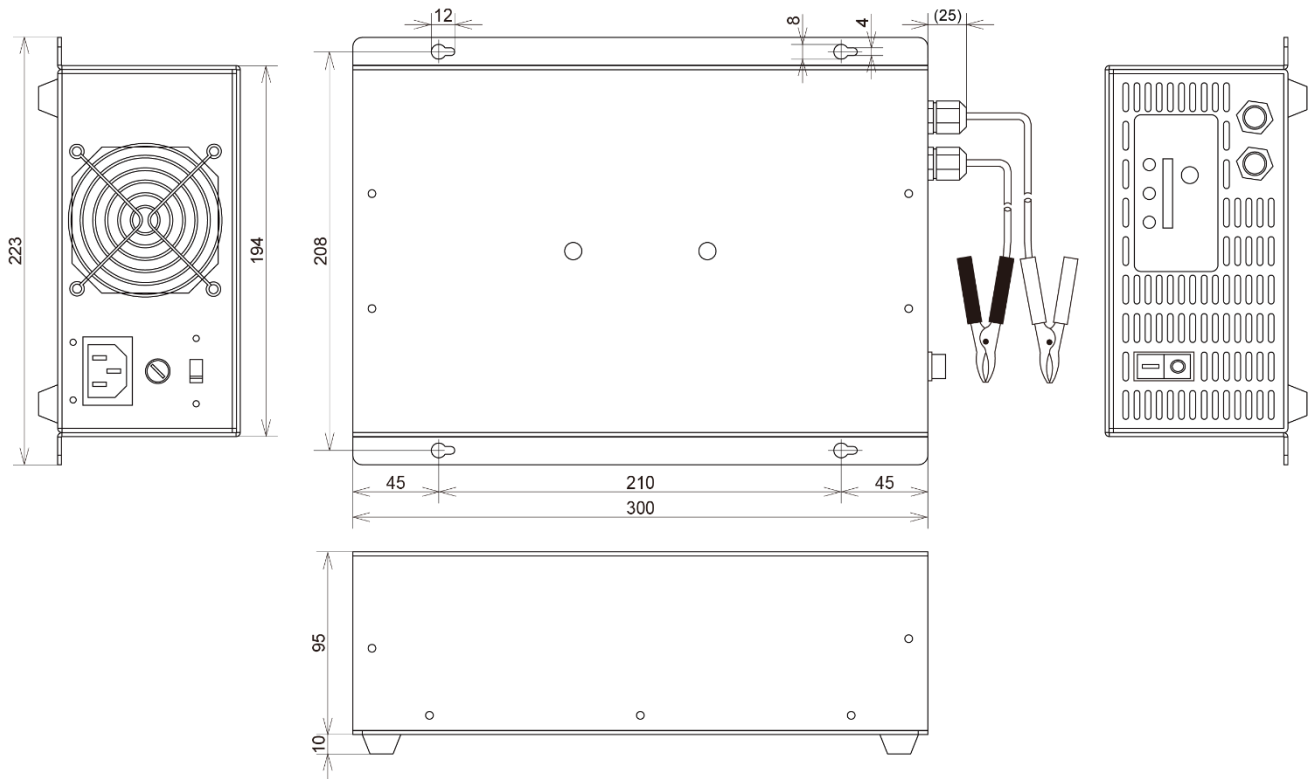

[mm]

2-2 Front Panel

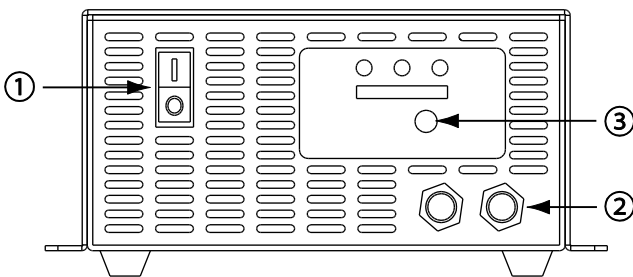

① **Power switch**

“ I ” : ON ; “ O ” : OFF

② **DC Output**

“ + ” : Red ; “ - ” : Black

③ **Charging voltage select button**

12V, 24V, 36V & 48V selectable

2-3 Rear Panel

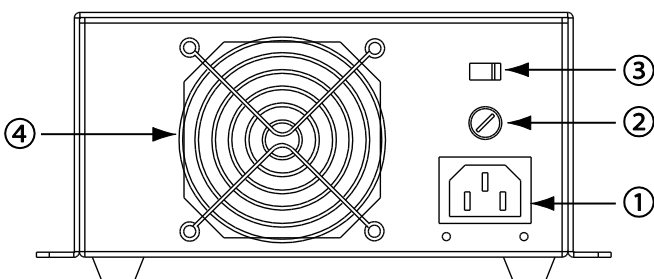

① **AC inlet**

Only use cord attached for AC input 100-120Vac. For AC input 200-240Vac, prepare a cable applies to 200-240Vac.

② **AC fuse holder**

20A/250Vac, ϕ 6.35mm, length 31.75mm fuse built-in.



NOTE

Please replace the fuse with the same specification if replacement is required.

③ AC Input voltage switch

AC 115/230Vac adjustable

Set "115" for input 90-120Vac; set "230" for input 180-240Vac.



NOTE

Set the switch with voltage as same as the AC input. DO NOT input 200Vac under the setting of 115.

④ Cooling fan

Fan works when charger temperature rises; fan stops when charger temperature drops.

Fan working depends on the different stages of rising temperature.



WARNING

PANcharge1k cools down by ventilation flows through the internal and extracted by fan. Always locate charger in a well-ventilation location to make sure it keeps cooling down. If charger temperature is too high that makes the protection function work; charger may stop working.

2-4. Specification

Model	PANcharge1k			
Input voltage	115/ 230Vac			
Input voltage range	90~120Vac/ 180~240Vac			
Input frequency	50/ 60Hz			
No-load current	Less than 0.1A			
Max Efficiency (Full-load)	80% (Average)			
Full-load Current	Less than 20A (Average)			
Battery voltage	12V	24V	36V	48V
Charging voltage range	8V~14.8V	16V~29.6V	30V~42V	40V~60V
Charging voltage	14.5V	29V	43.5V	58V
Float voltage	13.8V	27.6V	41.4V	55.2V
Max. charging current	30A	30A	25A	15A
Absorption min. current	2.25A	2.25A	2.25A	2.25A
Battery type	Lead-acid battery			
Normal temperature	25°C			
Operating temperature	0~40°C			
Storage temperature	-20~60°C			
Case temperature	Less than 70°C			
Humidity	5~95% RH (Non-condensing)			
AC input code	3P-2P Power code with earth wire, 2,600mm			
DC output code	Red (+)/ Black (-) with clips, 1,080mm			
Dimensions	300x223x95.3mm (Without foots and handle)			
Weight	3.8kg			

3. Installation and Settings

3-1. Installation location

- Place PANcharge1k in a dry and clean area with well ventilation. Save at least 10 cm distance from the charger.
- Place in an area with ambient temperature 0°C ~40°C.
- Locate charger as far away from battery as the DC cables permit. Set charger in a safe location far away from the risk of firing and gasoline.
- Set PANcharge1k in a horizontal position as far as possible.

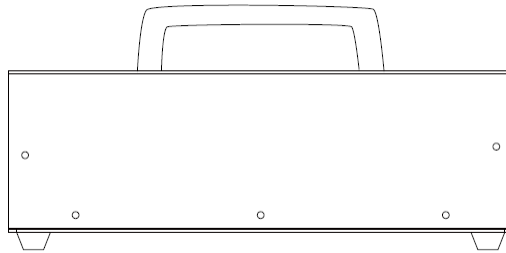

Picture 3-1 Mounting drawing.

3-2. Battery Type

PANcharge1k can charge lead acid batteries includes sealed lead acid battery and non-sealed lead acid battery. Charging non lead acid batteries or lead acid batteries with higher capacity than the list below may cause charger broken. In this case, the warranty is not applied.



WARNING

Only charge batteries within the capacity list below.

Charge voltage/ Max charge current	Capacity of battery (Min.~ Max.)
12V / 30A	60 ~ 300Ah
24V / 30A	60 ~ 300Ah
36V / 25A	50 ~ 250Ah
48V / 15A	30 ~ 150Ah

3-3. Connection and Setting

Step 1. Make sure power switch is off.

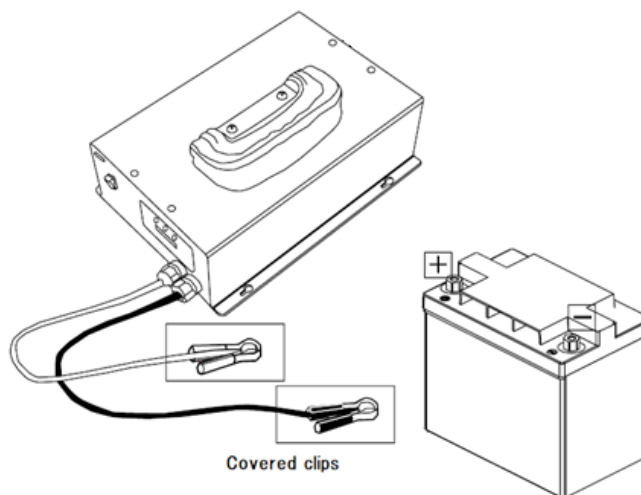

Step 2. Make sure nothing is connecting to charging clips.

 WARNING	<p>Do not connect battery before setting charging voltage. Moreover, to prevent short circuit of charging clips, cover the clips when it is disconnected anything.</p>
--	--



Picture 3-2 Covered clips

Step 3. Set AC input voltage switch 115 when input 90-120Vac; set 230 when input 180-240Vac.

115Vac	Input voltage	230Vac
	Setting	

 WARNING	<p>The AC power voltage setting must to be set as same as the input voltage. Never input 230Vac under the setting of 115Vac.</p>
--	--

Step 4. Make sure the AC input voltage switch is setting correctly.

Step 5. Make sure grounding wire on the plug of AC power cable grounds properly. Plug AC power cord into connector in the rear of charger. Make sure AC power cable is plugging into connector (3P) firmly. Connect plug of AC power cord to power outlet.

 WARNING	<p>Risk of electric shock. Ground grounding wire on the plug of AC power cable properly. Improper connection may cause risk of electric shock.</p>
--	--

Step 6. Press I on the AC power switch to turn charger on.

Step 7. All LED indicators light for 2 seconds. Afterward, red LED flashes indicate the charging clips is disconnecting to battery. The rectangle LED indicates the set charging voltage.

Step 8. Set charging voltage by pressing the switch key around 0.5 seconds. The setting order is 12V → 24V → 36V → 48V → 12V.... The number of rectangle LED lights reflects to the charging voltage user chose.

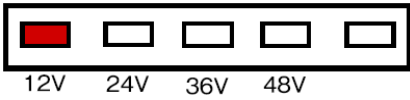
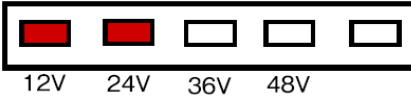
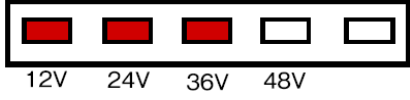
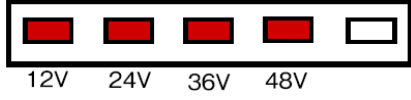
12V	Setting	24V
 <p>12V 24V 36V 48V</p>	LED status	 <p>12V 24V 36V 48V</p>
36V	Setting	48V
 <p>12V 24V 36V 48V</p>	LED status	 <p>12V 24V 36V 48V</p>

	NOTE	The charging voltage must to be set as same as the battery voltage.
---	-------------	---

Step 9. Press O on the AC power switch to turn charge off. The battery charging voltage setting is done.

Step 10. Connect charging clips to battery and turn on the power switch.

4. Operation

PANcharge1k is a charging voltage adjustable battery charger. The charging voltage is able to be switched in accordance with the battery voltage of 12V, 24V, 36V or 48V by the battery voltage setting switch on the charger.

4-1. 3 Stage Charging

PANcharge1k charges by the 3 stage charging: bulk, absorption charging and floating charging. In bulk charging stage, PANcharge1k outputs and charges by a constant current. In absorption charging stage, battery voltage is constant but the current is decreasing, and battery generates gas.

In the last stage of floating charging, charger charges with constant low voltage, maintains the battery at 100% state of charge. If the battery does not connect to any load, it is normally charged with a very low current.

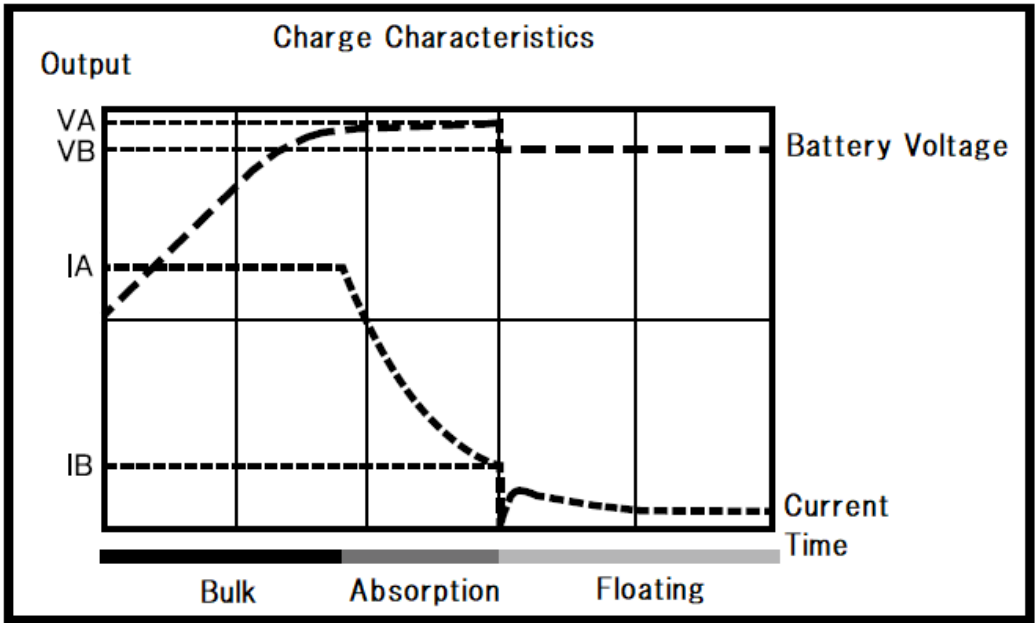

Picture 4-1 Charge Characteristics

Table 4-1 Charging Status LED Indicator

3 stage charging	Bulk	Absorption	Floating
Round LED indicator	Yellow	Yellow	Green
	Light up	Flash fast	Flash slowly
	↓	↓	↓
	Flash slowly	Flash very fast	Flash fast

Table 4-2 3 Stage Charging Voltage & Current

Charging voltage & current		Battery voltage			
		12V	24V	36V	48V
VA	Charging voltage	14.5V	29V	43.5V	58V
VB	Floating voltage	13.8V	27.6V	41.4V	55.2V
IA	Max charging current	30A	30A	25A	15A
IB	Ending current of absorption	2.25A	2.25A	2.25A	2.25A

4-2. Operation and LED Indicators

Step 1. Make sure the AC power voltage switch is correct set.

Step 2. Make sure the AC power switch is OFF and check the charging voltage setting is correct.

Step 3. Connect positive charging clip (red) to positive terminal of battery.

Step 4. Connect negative charging clip (black) to negative terminal of battery.

Step 5. Press I on the AC power switch to turn charger ON.

Step 6. All the LED light up for 2 seconds. Afterward, red LED lights up for 5 seconds. The rectangle LED indicates the set charging voltage.

Step 7. Charging begins. The relay in the charger turns ON. A clink sound is normal.

Step 8. Yellow round LED: light up constantly

The LED lights yellow for 25 seconds means charging just begins and is charging slowly. At the time, rectangle LED all light up initially, and turn to display the percentage of battery capacity charged by the amount it lights.

Step 9. Yellow round LED: flash slowly

The LED turns to flash yellow slowly means it is charging in a constant current, the bulk charging stage. At the time, the numbers rectangle LED light up increases with the capacity has been charged.

Step 10. Yellow round LED: flash quickly

The LED turns to flash yellow quickly means it is charging in a constant voltage, the absorption charging stage. At the time, the numbers rectangle LED light up increases with the capacity has been charged.

Step 11. Yellow round LED: flash very quickly

The LED turns to flash yellow more quickly means it is about to turn to floating charging stage soon.

Step 12. Green round LED: flash slowly

The LED turn to green means it has turned to the floating charging stage. Battery is full charged.

Step 13. Green round LED: flash quickly

The LED turn to flash green quickly means it is in the floating charging stage and charging current is beyond 0.5A.

Step 14. Battery charging is finished. Follow steps below to remove the battery.

- Turn charger OFF. The relay in the charger turns OFF. A clink sound is normal.
- Remove the black charging clip from battery, then remove the red one.

4-3. LED Indicator of Error

Times flashed (times)	Possible cause	Solution
2	<ul style="list-style-type: none"> Charging clips are not connecting to the battery. Fuse of output terminal is broken. 	<ul style="list-style-type: none"> Connect charging clips to the battery. Contact us or the distributor if charging clips connected and charger still errors.
3	The voltage of the Battery connected is too high or too low that exceeding the range of charging voltage.	Check if the battery voltage is available for the charger. (Refer to P.6)
4	The temperature sensor in the charger is short-circuited or opened.	The temperature sensor is error. Contact us or the distributor.
5	The internal temperature is too high that the over temperature protection is working.	Wait for the charger to cool down. It restarts automatically after temperature down.
6	Other problem is happened.	Contact us or the distributor.

4-4. Protection

- **Short-circuit protection:** It will not be damaged even the output terminal is short-circuited.
- **Reverse connection protection:** It will not be damaged even battery is reversely connected.
- **Over temperature protection:** Fan spins when charger internal temperature rises above a certain level, and switches to strong or weak automatically depending on the temperature. Fan stops when the temperature drops beyond a certain level. However, once the temperature rises higher than the general level, LED turns to error display. Leave it for a while and wait for the temperature drops to the normal level; charger recovers and charging restarts.
- **Input protection:** An abnormal current flow in internal charger because of the charge itself or other external factors, the protection works by melting the fuse of the input power.
- **Output protection:** Due to the trouble of charger itself or other external factors, abnormal current flows between the charger and battery. The fuse gets melt to protect the charger and safety.

5. Troubleshooting

Refer to the table below to solve the certain problems.

Problem	Possible cause	Solution
LED does not work even the AC power switch turns on.	AC power is not inputting.	Check if the AC power cord is connecting correctly.
	Fuse of AC power is broken	Check if fuse in the fuse holder in the rear of the panel is broken. If this problem still could not be fixed even the fuse is exchanged, contact us or the distributor.
	Charger defect	Contact us or the distributor.
Battery disconnected error even the charging clips are connecting to the battery. (Round LED flashes red for two times)	Bad connection between charging clips and battery terminals	Check if charging clips are connecting firmly
	Charger defect	Contact us or the distributor.
Temperature protection error displays and charging stops. (Round LED flashes red for five times)	Internal temperature is too high that the over temperature protection works	Locate the charger in a ventilation-well location and cool it down.
Battery could not be full charged even it has been charged over 24 hours. (Round LED flashes green)	Capacity of battery is too large for the charger	Change to a higher output charger.
	Current from battery is flowing to the load connected and the battery cannot be charged	Remove the load or turn the load off.
	The cell of battery is damaged	Change the battery.

6. Warranty

Thank you very much for your purchase. To make a claim under the warranty, confirm the User's manual to be certain that there is a problem with the product.

1. Please keep your warranty document. Without a warranty document, the warranty service is not valid. Upon modifying contents of this warranty document, the document is deemed to be invalid.
2. DENRYO CO., LTD. warrants original purchase against defects in material and workmanship for a period of ONE (1) years from Shipment Date to buyer. The extension shall in no case exceed ONE POINT FIVE (1.5) years in aggregate.
3. DENRYO CO., LTD. shall not warrant product under the following conditions:
 - *Damage by accident, negligence at operation, incorrect directions for use (e.g. Damage by not using with the exact way User's manual and original label noted)
 - *Damage by other devices are connected to our product
 - *Unauthorized remodel by other than our serviceperson
 - *Breakdowns due to the effects of natural disasters, pollution, salt damage
 - *Lack an original label includes serial number
 - *Made a claim after passing warranty period
 - *Damage by any transactional problems not attributable to DENRYO CO., LTD. (e.g. Damage by accident during transportation without other than our packing)
4. Buyer shall bear the shipping charge when return the defective products.

DENRYO CO., LTD. IS NOT RESPONSIBLE FOR INCIDENTAL OR CONSEQUENTIAL DAMAGES OF ANY KIND, INCLUDING BUT NOT LIMITED TO LOST PROFITS, DOWNTIME, GOODWILL OR DAMAGE TO EQUIPMENT OR PROPERTY.

Model Name : PANcharge1k

Serial No. :

Dealer :

Sale Date : (yyyy/mm/dd)

The logo for DENRYO, featuring a stylized lowercase 'd' symbol followed by the word 'DENRYO' in a bold, uppercase, sans-serif font.

DENRYO CO., LTD.

28-5, Nishinippori 2Chome, Arakawa-ku,
Tokyo 116-0013, Japan
Phone: +81-3-3802-3671
Fax: +81-3-3802-2974
Email: info-en@denryo.com
www.denryo.com/en